

Super Mist Separator

Series AME

Series AME separates and absorbs aerosol state fine oil particles in compressed air and changes the oil lubricating compressed air to oilless equivalent air. It should be applied for filtration of compressed air requiring high cleanliness for coating lines, compressed air for clean rooms and compressed air for equipment necessary to avoid oils.

Due to its special configuration, series AME indicates the life of the filter element by a color change. Accordingly, the replacing time can be judged visually. (A red color spot indicates the replacing time.)

By all means series "AM" should be used as a prefilter. Additionally the series "AMF" in the rear stage can produce a high quality compressed air as air source for clean room.



Model

Model	AME150	AME250	AME350	AME450	AME550	AME650	AME850
Rated flow (l/min (ANR)) ⁽¹⁾	200	500	1000	2000	3500	6000	12000
Port size (Nominal size B)	1/8, 1/4, 3/8	1/4, 3/8, 1/2	3/8, 1/2, 3/4	1/2, 3/4, 1	3/4, 1	1, 1 1/2	1 1/2, 2
Weight (kg)	0.38	0.55	0.9	1.4	2.1	4.2	10.5



Note 1) Max. flow capacity at a pressure of 0.7MPa. It varies depending on operating pressure. Refer to "Flow Characteristics" p.4.5-23 and figure of "Max. air flow" p.4.5-23.

Specifications

Fluid	Compressed air
Max. operating pressure	1.0MPa
Min. operating pressure	0.05MPa
Proof pressure	1.5MPa
Ambient and fluid temperature	5 to 60°C
Filtration	0.01μm(95% particle size collection)
Oil mist removal rate	Less than 3.5 particles 0.3 μm or larger per liter of air (100 particles or less per cubic foot)
Element life	Element Color Indicator (When element becomes saturated with oil the element surface changes from white to red.)

Accessories (Options)

Applicable models	AME150	AME250	AME350	AME450	AME550	AME650	AME850
Bracket assembly (With cap bolt, spring washer)	BM51	BM52	BM53	BM54	BM55	BM56	BM57

How to Order

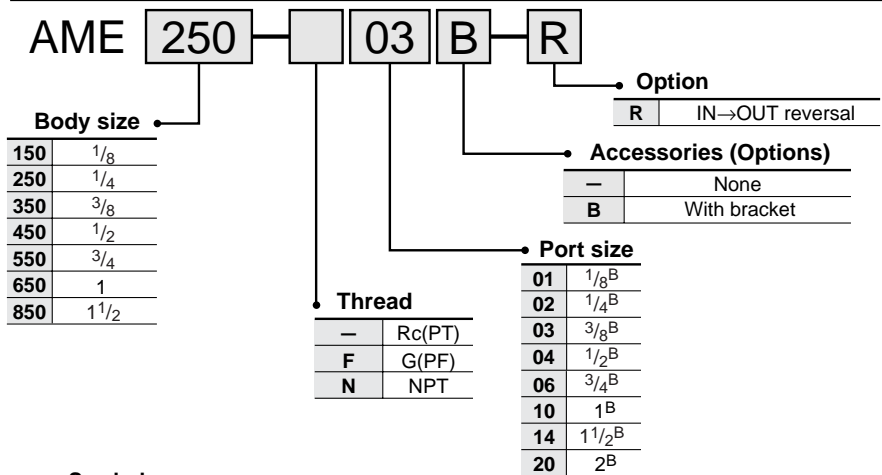

Note) Refer to p.4.6-6 for "How to Order" case assembly.

HA

ID

AMG

AFF

AM

FQ1

Related products

Series AME

Flow Characteristics

— Element initial condition



Note) Compressed air over max. flow line in the table below may not meet the specification of product. It may cause damage to the element.

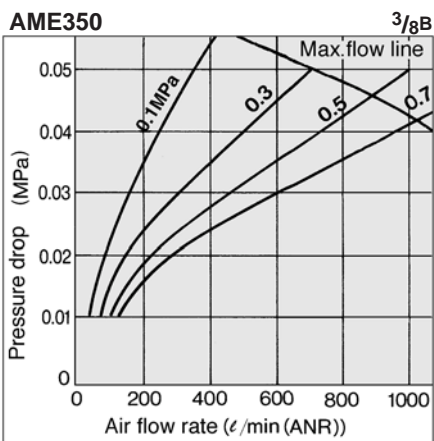
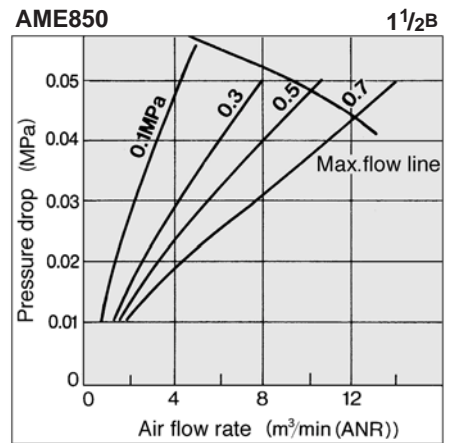
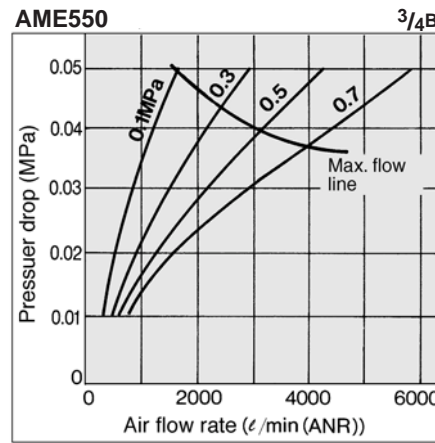
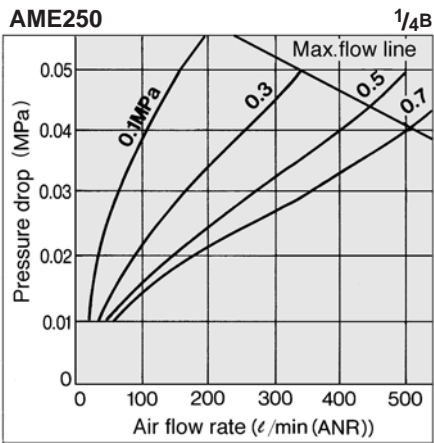
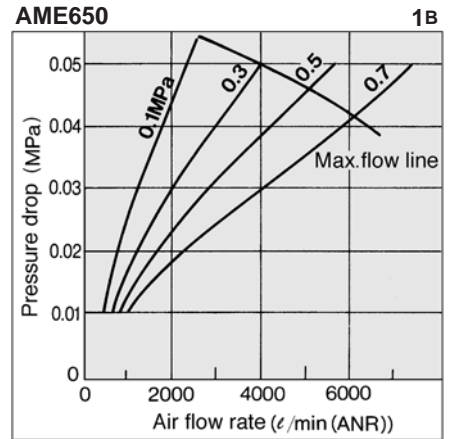
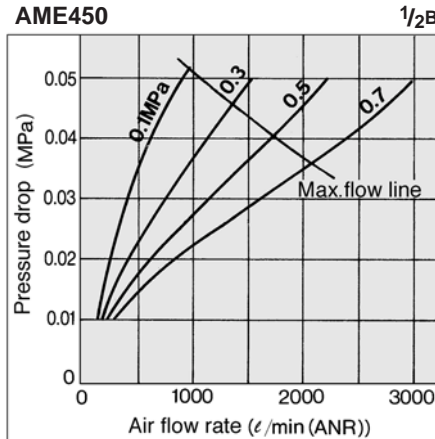
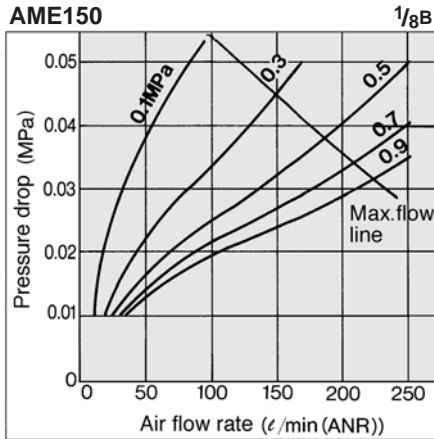

How to Select

Select the model in accordance with the following procedure taking the inlet pressure and max. air flow into consideration.

(Example) Inlet pressure: 0.6MPa
Max. air flow capacity: 5m³/min. (ANR)

- ① Select the point of contact A of inlet pressure and max. air capacity in the graph.
- ② Select the type whose max. air flow capacity is over that point; AME650.



Note: Make sure to select a model that has the maximum flow rate line above the obtained intersecting point. With a model that has the maximum flow rate line below the obtained intersecting point, the flow rate will be exceeded, thus leading to a problem such as being unable to satisfy the specifications.

Max. Air Flow

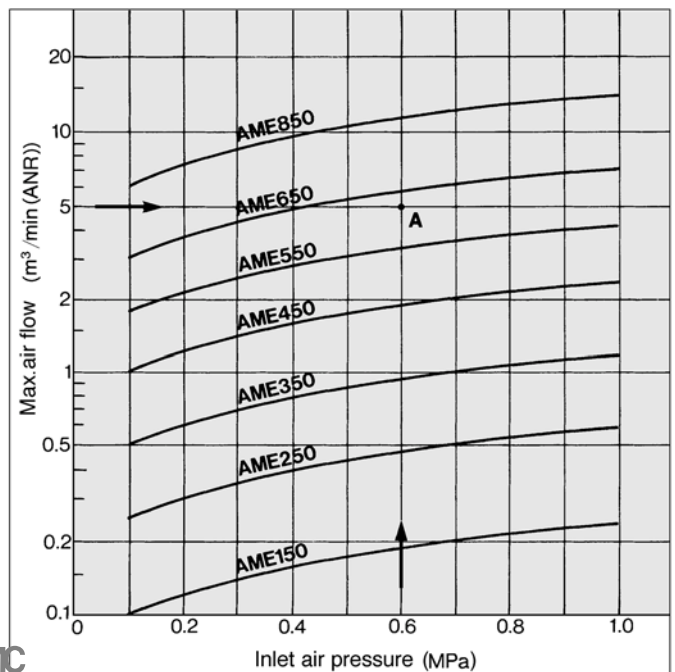

Construction

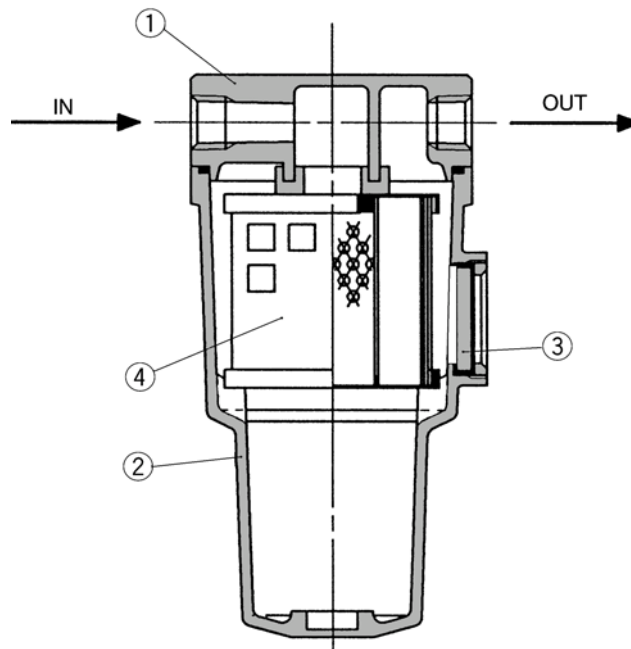

Component Parts

No.	Description	Material	Note
①	Body	Aluminum die cast	Chrome treatment
②	Housing	Aluminum die cast *	Epoxy coating on inner surface
③	Sight glass	Tempered glass	

* AM850 is aluminum casting.



Note) Sight glass is indicated in the figure above for easy understanding of parts, however mounting position is different. Refer to dimensions p.4.5-25 and 4.5-26 for details.

Replacement Parts

No.	Description	Material	Part No.						
			AME150	AME250	AME350	AME450	AME550	AME650	AME850
④	Element assembly	Glass fiber NBR	AME-EL150	AME-EL250	AME-EL350	AME-EL450	AME-EL550	AME-EL650	AME-EL850

* With gasket and O ring

⚠ Precautions

Be sure to read before handling. Refer to p.0-26 and 0-27 for Safety Instructions and common precautions on the products mentioned in this catalogue, and refer to p.4.0-5 to 4.0-7 for more detailed precautions of every series.

Design

⚠ Caution

- Do not use this product in a line in which the pressure pulsation cycle is frequent. If it must be used under such conditions due to unavoidable circumstances, contact SMC beforehand.
- Do not use it with anything other than dry air (such as air containing moisture). If it is used with anything other than dry air (such as air containing moisture), the drainage will flow in, and the color change indicator function will not operate properly.
- Make sure to install a mist separator (AM Series), a micromist separator (AMD Series), or a micromist separator with a prefilter (AMH Series) on the primary side.
- The bracket that is provided with the product is for supporting the product itself. Thus, it cannot support the piping or other items that are connected. If these items need to be supported, provide an additional support.

Mounting

⚠ Caution

- Verify the direction of the flow of the compressed air and the "▷" mark that indicates the inlet of the product before connecting. It cannot be used if connected in the opposite direction.

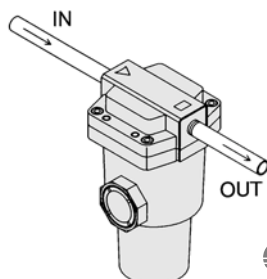

- Make sure to install this product on horizontal piping. If it is installed diagonally, laterally, or upside down, the drainage that is separated by the element will splash to the secondary side.

Maintenance

⚠ Caution

- If red spots appear on the element surface, it is time to replace the element. Immediately replace it with a new element. Make sure to replace the O ring and the gasket together with the element. The element can be seen through the sight glass in front of the mist separator body. Make sure to inspect it at least once a day, and pay particular attention to the replacement interval of the element. Also, it is recommended to install a check filter just in case the red spots on the element surface are overlooked. (Example: install an additional AME, thus placing two of them inline.)
- Even if the red spots do not appear on the element surface, the replacement interval for the element is when the pressure drop reaches 0.1MPa or after 2 years of operation, whichever comes first.
- If the element continues to be used past its replacement interval, the element could become damaged. If the element continues to be used after the red spots have appeared on its surface, the red-dyed oil mist will splash to the secondary side.

HA

ID

AMG

AFF

AM

FQ1

Related products

Series AME

Dimensions: AME150 to AME350

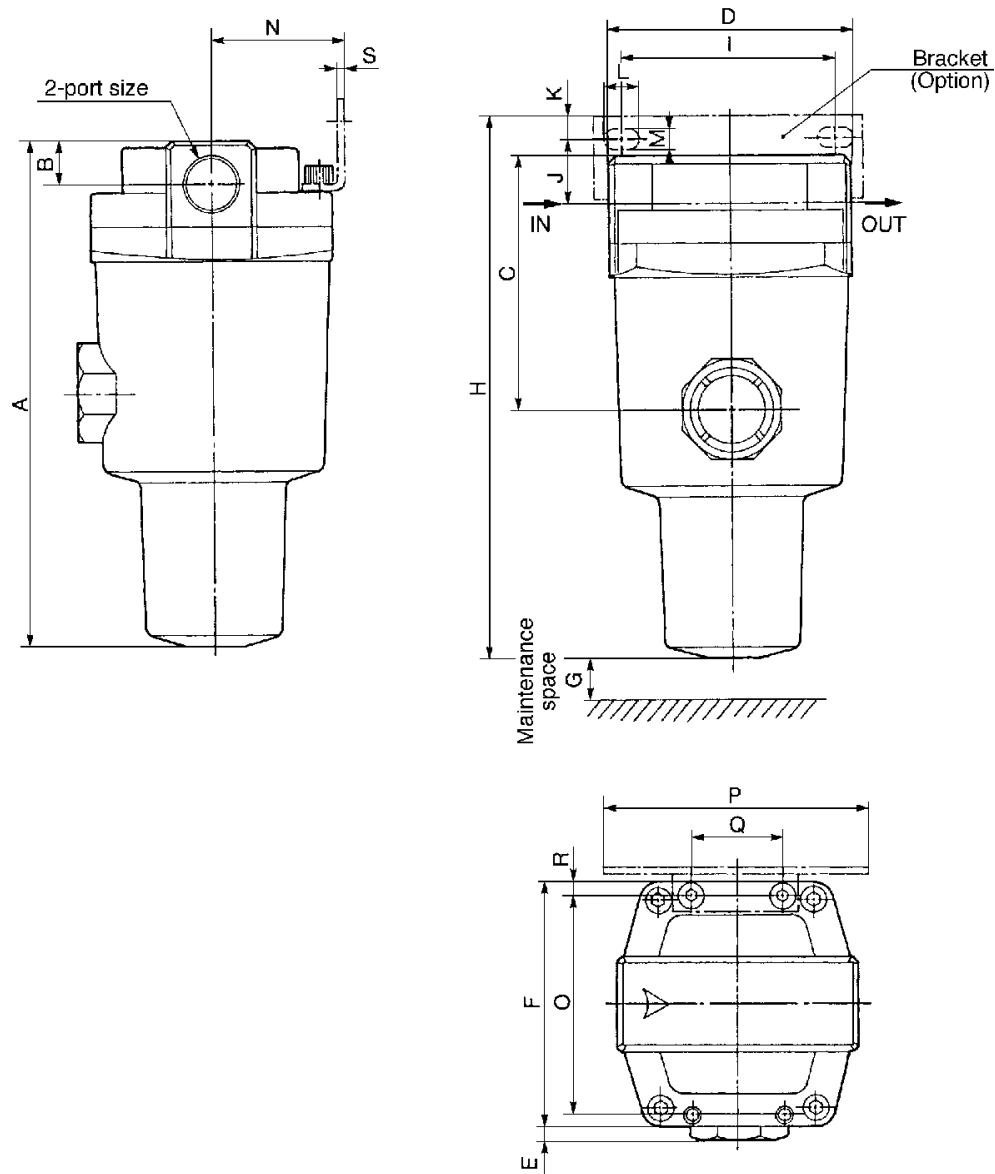

Model	Port size (Nominal size B)	A	B	C	D	E	F	G	Dimensions with mounting bracket											
									H	I	J	K	L	M	N	O	P	Q	R	S
AME150	1/8, 1/4, 3/8	139	13	55	63	7.5	63	10	146	56	15	5	9	5.5	35	54	70	26	4.5	1.6
	1/4, 3/8	152	13	66	76	4	76	10	167	66	20	8	12	6	40	66	84	28	5	2.0
AME250	1/2	158	16	72	76	4	76	10	167	66	17	8	12	6	40	66	84	28	5	2.0
	3/8, 1/2	184	16	92	90	5	90	10	198	80	22	8	14	7	50	80	100	34	5	2.3
AME350	3/4	190	19	98	90	5	90	10	198	80	19	8	14	7	50	80	100	34	5	2.3

Super Mist Separator Series **AME**

Dimensions: AME450 to AME850

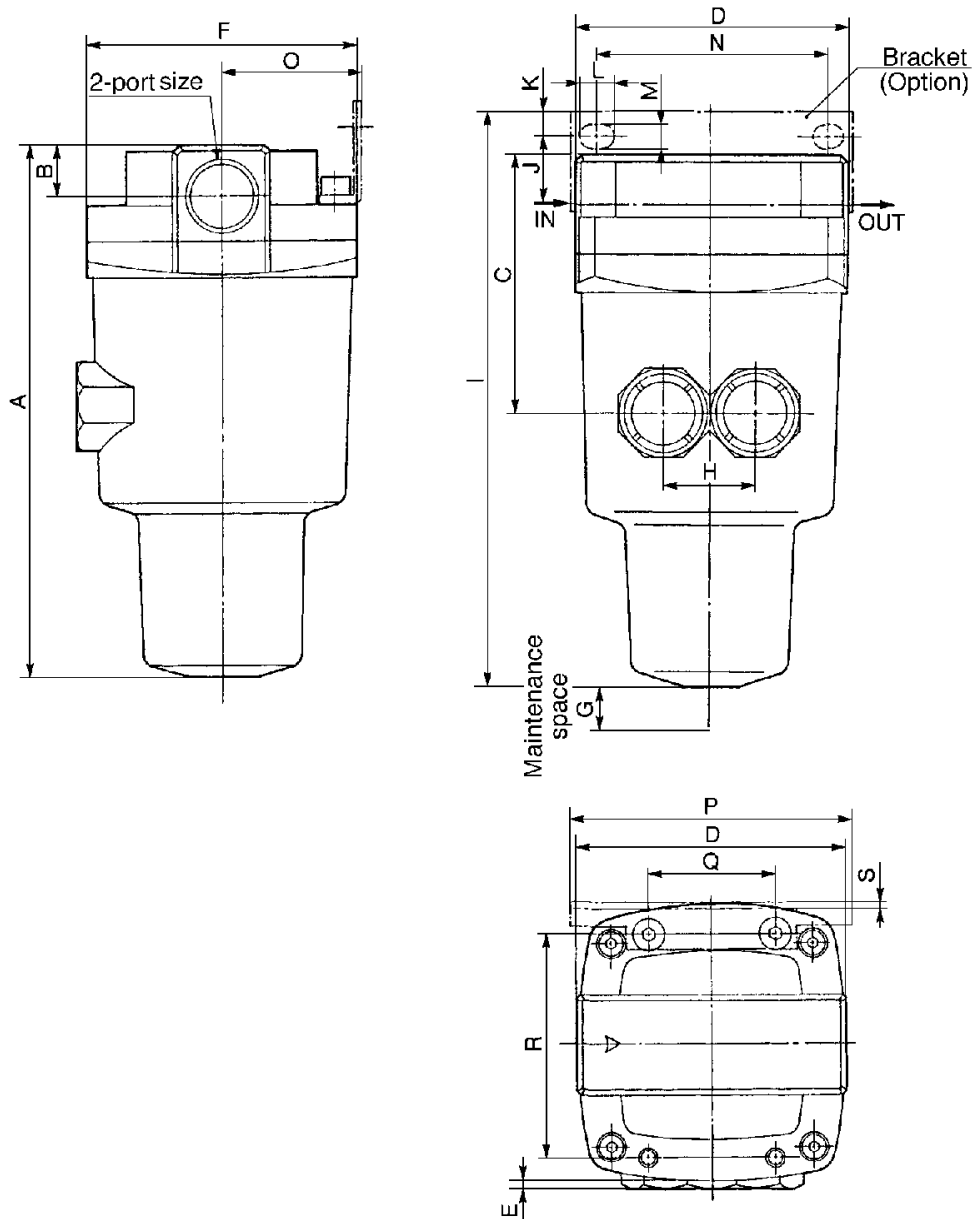

Model	Port size (Nominal size B)	A	B	C	D	E	F	G	H	Dimensions with mounting bracket										
										I	J	K	L	M	N	O	P	Q	R	S
AME450	$\frac{1}{2}, \frac{3}{4}$	205	19	100	106	3	106	10	36	221	25	10	14	9	90	55	110	50	88	3.2
	1	212	22	107	106	3	106	10	36	221	21	10	14	9	90	55	110	50	88	3.2
AME550	$\frac{3}{4}, 1$	239	22	128	122	3	122	10	44	257	30	10	16	9	100	65	130	60	102	4.5
AME650	1, 1 $\frac{1}{2}$	291	32	167	160	—	160	10	66	314	40	15	20	11	150	85	180	76	136	4.5
AME850	1 $\frac{1}{2}$, 2	403	42	235	220	—	220	10	96	406	30	15	24	13	180	120	220	110	184	6

HA

ID

AMG

AFF

AM

FQ1

Related products