

Air Suction Filter In-line Type with One-touch Fittings *Series ZFC*



An in-line type air suction filter that prevents trouble in vacuum equipment due to contaminants in the air

IN/OUT straight piping

Saves space with space efficient straight piping

One-touch fittings for easy installation and removal

Piping tubes can be attached or detached with one touch

Applicable tubing sizes

Metric sizes (release bushing: light gray)

ø4, ø6, ø8

Inch sizes (release bushing: orange)

ø5/32", ø1/4", ø5/16"

Light weight molded resin parts

Cartridge type allows element replacement

The cover can be opened with one touch to allow quick replacement without tools while still connected to piping

Air Suction Filter

In-line Type with One-touch Fittings

Series ZFC



Models

Model		Port size (applicable tube O.D.)		Recommended flow rate /min (ANR) ^{Note 1)}	Weight g
		IN side, OUT side			
Metric size	ZFC100-04	ø4		10	11.5
	ZFC100-06	ø6		20	
	ZFC200-06	ø6		30	21.5
	ZFC200-08	ø8		50	
Inch size	ZFC101-03	ø5/32"		10	11.5
	ZFC101-07	ø1/4"		20	
	ZFC201-07	ø1/4"		30	21.5
	ZFC201-09	ø5/16"		50	

Note 1) Flow rate when initial pressure drop is 0.003MPa or less.

Specifications

Fluid	Air, Nitrogen
Operating pressure	-100 to 0kPa
Withstand pressure	0.5MPa
Operating and ambient temperature range	0 to 60°C (with no freezing)
Filtration degree	10µm
Element differential pressure resistance	0.15MPa
Applicable tubing material	Nylon, Soft nylon, Polyurethane, Soft polyurethane

Note) Do not use in a line where a pressurized condition is maintained since the body may be damaged.

Symbol

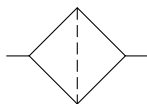

How to Order

ZFC 100 - 04 B

• Air suction filter
• In-line type with One-touch fitting

• With bracket (standard)
• IN/OUT applicable tube O.D.

• Type (recommended flow rate)

Tubing size	Symbol	Flow rate /min (ANR)
Metric size (release bushing: light gray)	100	Max. 20
	200	Max. 50
Inch size (release bushing: orange)	101	Max. 20
	201	Max. 50

Metric size

Symbol	Tubing size	Applicable model
04	ø4	ZFC100
06	ø6	ZFC100
		ZFC200
08	ø8	ZFC200

Inch size

Symbol	Tubing size	Applicable model
03	ø5/32"	ZFC101
07	ø1/4"	ZFC101
		ZFC201
09	ø5/16"	ZFC201

Element Part Numbers

Part No.	Applicable filter model	Element size mm
I-62S	ZFC100	ø12 x ø8 x L20
	ZFC101	
I-63S	ZFC200	ø16 x ø12 x L25
	ZFC201	

Note) When ordering spare elements, enter "-A" at the end of the part number.
Spare elements and O-rings for the cover are sold in sets of 10 pieces each.
Example) I-62S-A

Principal Materials

Description	Material
Case	Special transparent nylon
Cover	PBT
Element	PVF
O-ring, Seal	NBR

Application Examples

Fields: Semiconductors, electronics, automotive assembly, food processing and medical equipment, all types of manufacturing assembly equipment

Machinery: Robotic hand/material handling, automotive assembling machines, automatic transfer equipment, pick and place, printing machinery

Applications: Vacuum adsorption transfer, vacuum adsorption retention, vacuum generated air flow

Ejector system application

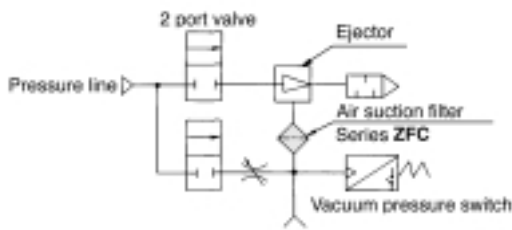

Vacuum pump system application

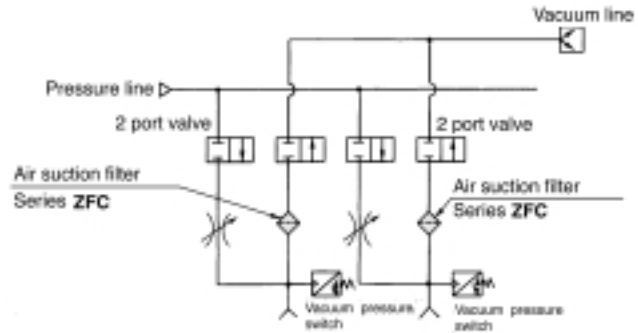

Flow Rate Characteristics (Piping tube: Metric size, Inch size)

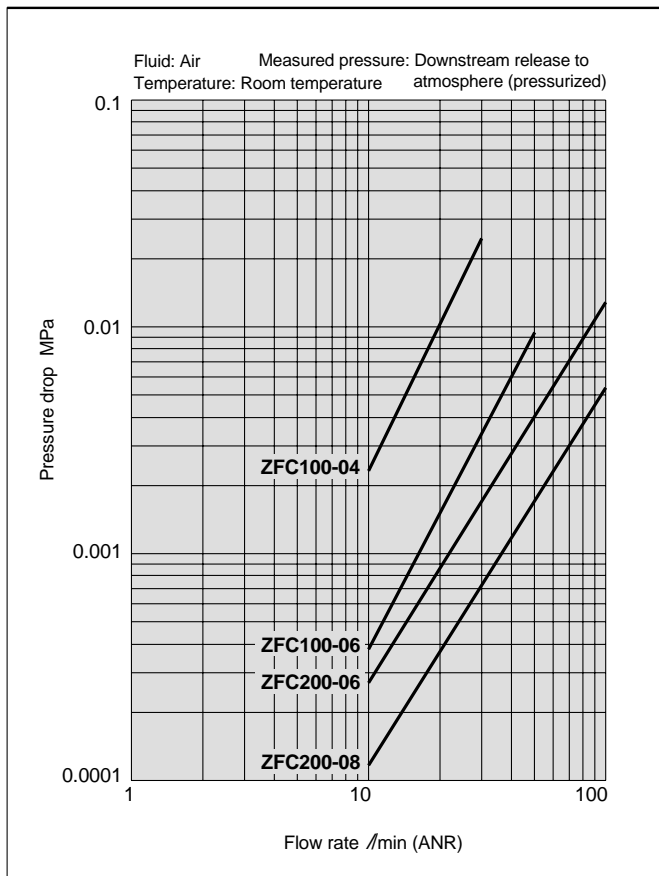

Construction

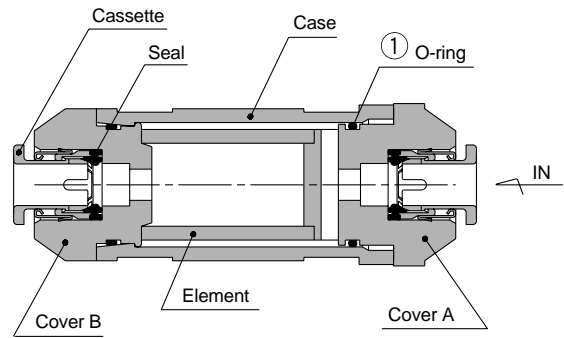

Replacement parts

No.	Description	Part No.	
		ZFC100, 101	ZFC200, 201
①	O-ring	S10	S14
Accessory	Bracket	BP-16S	BP-17S

* O-rings are already installed in spare elements.
A bracket is included with the product.

Series ZFC

Dimensions

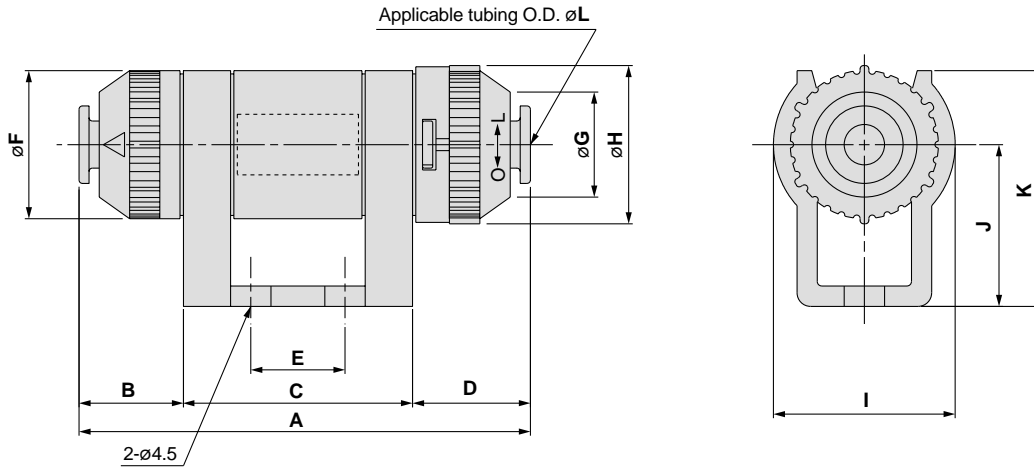

Model	A	B	C	D	E	F	G	H	I	J	K	L
ZFC100-04	53.2	9.1	30	14.1	10	18	11.6	19.5	23	20	29	4
ZFC100-06												6
ZFC101-03												5/32"
ZFC101-07												1/4"
ZFC200-06	67	15.5	34	17.5	14	22	15.6	23.1	27	24	35	6
ZFC200-08												8
ZFC201-07												1/4"
ZFC201-09												5/16"

Element Replacement

Element replacement procedure

- 1) Stop operation and reduce the filter's internal pressure to atmosphere.
- 2) Turn cover A counter clockwise until it stops (approx. 45°).

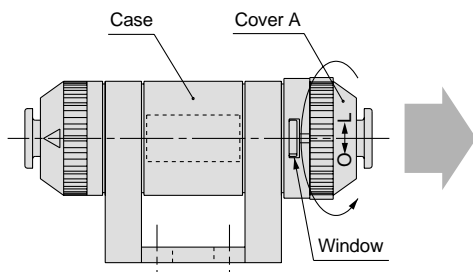

- 3) Pull cover A out of the case and remove the element. Remove dust and other debris remaining inside the case by blowing it out with air, etc. (Also confirm that the O-ring is not damaged.)

- 4) Install a new element on cover A and insert it into the case.

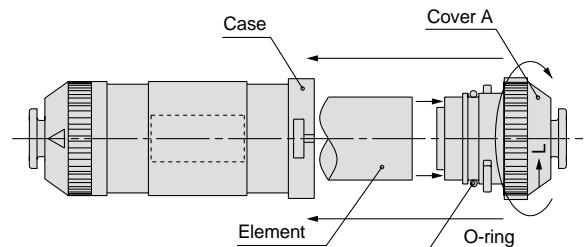

- 5) After aligning the projections (2 places) on cover A with the grooves in the case, push cover A in and turn it clockwise until it stops (approx. 45°). (Confirm that the projections on cover A can be seen completely through the windows in the case.)
- 6) Restart operation.

Related Products
Air Suction Filter
Series ZFA/ZFB



For details on the air suction filter series ZFA/ZFB, refer to catalogs E803-B "ZFA" and E809-A "ZFB".

Models

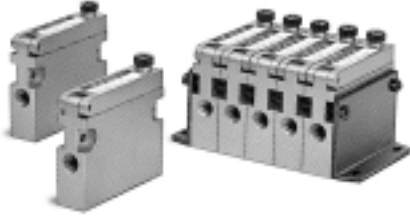

ZFA100

Model		Port size (applicable tube O.D.)	Recommended flow rate	Weight
			/min (ANR)	g
High flow rate square type	ZFA100	1/8	50	140
	ZFA200	1/4	200	190
Universal type	ZFB10□	ø4, ø6, ø3/16", ø1/4"	10 to 20	22
	ZFB20□	ø6, ø8, ø1/4"	30 to 50	30
	ZFB30□	ø10, ø3/8"	75	40
	ZFB401	ø1/2"	100	62

Specifications



ZFB



Fluid	Air, Nitrogen
Operating pressure	Negative pressure
Withstand pressure	0.5MPa
Operating and ambient temperature range	0 to 60°C (with no freezing)
Filtration degree	30µm
Element differential pressure resistance	0.15MPa
Applicable tubing material	Nylon, Soft nylon, Polyurethane, Soft polyurethane

Note) Do not use series ZFB in a line where a pressurized condition is maintained, since the body may be damaged.



Series ZFC Safety Instructions

These safety instructions are intended to prevent a hazardous situation and/or equipment damage. These instructions indicate the level of potential hazard by labels of "Caution", "Warning" or "Danger". To ensure safety, be sure to observe ISO 4414 ^{Note 1)}, JIS B 8370 ^{Note 2)} and other safety practices.

-  **Caution** : Operator error could result in injury or equipment damage.
-  **Warning** : Operator error could result in serious injury or loss of life.
-  **Danger** : In extreme conditions, there is a possible result of serious injury or loss of life.

Note 1) ISO 4414 : Pneumatic fluid power – Recommendations for the application of equipment to transmission and control systems

Note 2) JIS B 8370 : General Rules for Pneumatic Systems

Warning

1. The compatibility of pneumatic equipment is the responsibility of the person who designs the pneumatic system or decides its specifications.

Since the products specified here are used in various operating conditions, their compatibility for the specific pneumatic system must be based on specifications or after analysis and/or tests to meet your specific requirements.

2. Only trained personnel should operate pneumatically operated machinery and equipment.

Compressed air can be dangerous if an operator is unfamiliar with it. Assembly, handling or repair of pneumatic systems should be performed by trained and experienced operators.

3. Do not service machinery/equipment or attempt to remove components until safety is confirmed.

1. Inspection and maintenance of machinery/equipment should only be performed after confirmation of safe locked-out control positions.
2. When equipment is to be removed, confirm the safety process as mentioned above. Cut the supply pressure for this equipment and exhaust all residual compressed air in the system.
3. Before machinery/equipment is restarted, take measures to prevent shooting-out of cylinder piston rod, etc. (Bleed air into the system gradually to create back pressure.)

4. Contact SMC if the product is to be used in any of the following conditions:

1. Conditions and environments beyond the given specifications, or if product is used outdoors.
2. Installation on equipment in conjunction with atomic energy, railway, air navigation, vehicles, medical equipment, food and beverages, recreation equipment, emergency stop circuits, press applications, or safety equipment.
3. An application which has the possibility of having negative effects on people, property, or animals, requiring special safety analysis.



Series ZFC Vacuum Equipment Precautions 1

Be sure to read before handling.

Selection

Warning

1. Confirm the specifications.

The products appearing in this catalog are designed for use only in compressed air systems (including vacuum). Do not use outside the specified ranges of pressure, temperature, etc., as this may cause damage or malfunction. (Refer to specifications.) Consult with SMC if fluids other than compressed air (including vacuum) are to be used.

Mounting

Warning

1. Read the instruction manual carefully.

The product should be mounted and operated with a good understanding of its contents. Also, keep the manual where it can be easily referred to at any time.

2. Ensure space for maintenance.

Ensure the necessary space for maintenance activities.

Piping

Caution

1. Preparation before piping

Before piping is connected, it should be thoroughly blown out with air (flushing) or washed to remove chips, cutting oil and other debris from inside the pipe.

Air Supply

Warning

1. Types of fluid

This product is designed for use with compressed air. Consult with SMC if a different fluid is to be used.

Contact SMC regarding products to be used with general purpose fluids, to confirm which fluids may be used.

2. Types of air

Do not use compressed air containing chemicals, synthetic oil which includes organic solvents, salt, corrosive gases etc., as this may cause damage or malfunction.

Operating Environment

Warning

1. Do not operate in locations having an atmosphere of corrosive gases, chemicals, sea water, fresh water or water vapor, or where there will be contact with the same.
2. In locations which receive direct sunlight, the sunlight should be blocked.
3. Do not operate in locations where vibration or impact occurs.
4. Do not operate in locations near heat sources where radiated heat will be received.

Maintenance

Warning

1. Perform maintenance in accordance with procedures in the instruction manual.
Improper handling may cause damage or malfunction of equipment or machinery.
2. Maintenance work
Improper handling of compressed air is dangerous. Therefore, in addition to observing the product specifications, replacement of elements and other maintenance activities should be performed by personnel having sufficient knowledge and experience pertaining to pneumatic equipment.
3. Pre-maintenance inspection
When removing this product, turn off the electric power, and be certain to shut off the supply pressure and release the vacuum. Proceed only after confirming that all pressure has been released to atmosphere.
4. Post maintenance inspection
After installation, perform inspections for proper operation and air leakage. If the sound of air leakage can be heard, or if the equipment does not operate properly, stop operation and confirm that it is mounted correctly.
5. Disassembly and alteration prohibited.
Do not disassemble the unit or make any alterations to it.



Series ZFC Vacuum Equipment Precautions 2

Be sure to read before handling.

Design & Selection

⚠ Warning

1. **Devise a safe design which addresses the possibility of accidents resulting from a drop in vacuum pressure due to power failure or trouble with the air supply, etc.**

If vacuum pressure drops and there is a loss of vacuum pad adsorption force, work pieces being carried may fall, causing a danger of human injury and damage to machinery. Safety measures should be implemented, such as the installation of drop prevention guides.

2. **Use vacuum specifications for vacuum switching valves and vacuum release valves.**

If valves which do not meet vacuum specifications are installed in vacuum piping, vacuum leakage will occur. Be certain to use vacuum specification valves.

3. **Select ejectors which have a suitable suction flow rate.**

<When there is a vacuum leak from the work piece or the piping>

If the ejector's suction flow rate is too low, this will cause poor adsorption.

<When piping is long or of large diameter>

The adsorption response time will increase due to the increased volume of the piping.

Select ejectors with a suitable suction flow rate by referring to their technical data.

4. **If the suction flow rate is too high, setting of vacuum switches will become difficult.**

In the case of adsorption on a small work piece of only a few millimeters, if an ejector is selected which has a high suction flow rate, the pressure difference when adsorbing and releasing the work piece is small. Since setting of the vacuum switch may become difficult, an appropriate ejector should be selected.

5. **When two or more pads are piped to one ejector, if one pad releases its work piece, the other pads will also release.**

When one pad is removed from its work piece, there is a drop in vacuum pressure which causes the other pads to release their work pieces also.

6. **Use piping with an adequate effective sectional area.**

Select piping for the vacuum side which has an adequate effective sectional area, so that the ejector's maximum suction flow rate can be accommodated by the piping.

Also, make sure that there are no unnecessary restrictions or leaks, etc. along the course of the piping.

The piping on the air supply side must be designed so that it corresponds to each ejector's air consumption. The effective sectional area of tubing, fittings and valves, etc., should be sufficiently large, and the pressure drop reaching the ejector should be kept to a minimum.

Further, design of the air supply should take into consideration the ejector's maximum air consumption and the air consumption of other pneumatic circuits.

⚠ Caution

1. **For information on related items, such as directional control equipment and drive equipment, refer to the caution sections in each respective catalog.**

Mounting

⚠ Warning

1. **Do not obstruct the exhaust port of the ejector.**

If the exhaust port is obstructed when mounted, a vacuum will not be generated.

Piping

⚠ Caution

1. **Avoid disorganized piping.**

Use piping which is direct and of the shortest possible length for both the vacuum and supply sides, and avoid disorganized piping. Unnecessary length increases the piping volume, and this increases the response time.

2. **Use piping having a large effective sectional area on the exhaust side of the ejector.**

If the exhaust piping is restrictive, there will be a decline in the ejector's performance.

3. **Make sure that there are no crushed areas in the piping due to damage or bending.**

Operating Environment

⚠ Warning

1. **Do not operate in locations having an atmosphere of corrosive gases, chemicals, sea water, water or steam, or where there will be contact with the same.**

2. **Do not operate in locations having an explosive atmosphere.**

3. **Do not operate in locations where vibration or impact occurs.**

Confirm the specifications for each series.

4. **In locations which receive direct sunlight, provide a protective cover, etc.**

5. **In locations near heat sources, block off any radiated heat.**

6. **In locations where there is contact with water, oil or welding spatter, etc., implement suitable protective measures.**

7. **In cases where the vacuum unit is surrounded by other equipment, etc., or it is energized for an extended time, implement measures to radiate excess heat so that temperatures remain within the range of specifications.**

Maintenance

⚠ Warning

1. **Clean suction filters and silencers on a regular basis.**

The performance of ejectors will deteriorate due to clogging in filters and silencers. Large capacity filters should be used, especially in dusty locations.



Series ZFC Fitting and Tubing Precautions

Be sure to read before handling.

Mounting

⚠ Caution

1. Before mounting confirm the model and size, etc.
Also confirm that there are no blemishes, nicks or cracks in the product.
2. When connecting a tube, consider factors such as changes in the tubing length due to pressure, and allow sufficient leeway.
3. Mount so that fittings and tubes are not subjected to twisting, pulling or moment loads. This can cause damage to fittings and flattening, bursting or separation of tubing, etc.
4. Mount so that tubing is not damaged due to tangling or abrasion. This can cause flattening, bursting or separation of tubing, etc.

Operating Environment

⚠ Warning

1. Do not use in environments where there is direct contact with liquids such as cutting oil, lubricating oil or coolant oil, etc. Contact SMC regarding use in environments where there will be direct contact with cutting oil, lubricating oil or coolant oil, etc.

Maintenance

⚠ Caution

1. Make periodic inspections to check for the following problems, and replace parts as necessary.
 - a) Blemishes, Nicks, Abrasion, Corrosion
 - b) Air leakage
 - c) Twisting, flattening or tangling of the tubing
 - d) Hardening, deterioration or softening of the tubing
2. Do not attempt to patch or repair fittings and tubing which have been replaced.

Precautions for One-touch Fittings

⚠ Caution

1. Tube attachment/detachment for One-touch fittings
 - 1) Attaching of tube
 1. Take a tube having no flaws on its periphery and cut it off at a right angle. When cutting the tube, use tube cutters TK-1, 2 or 3. Do not use pinchers, nippers or scissors, etc. If cutting is done with tools other than tube cutters, the tube may be cut diagonally or become flattened, etc. This can make a secure installation impossible, and cause problems such as the tube pulling out after installation or air leakage. Allow some extra length in the tube.
 2. Grasp the tube and push it in slowly, inserting it securely all the way into the fitting.
 3. After inserting the tube, pull on it lightly to confirm that it will not come out. If it is not installed securely all the way into the fitting, this can cause problems such as air leakage or the tube pulling out.
 - 2) Detaching of tube (ZFC200, 201)
 1. Push in the release bushing sufficiently. When doing this, push the collar evenly.
 2. Pull out the tube while holding down the release bushing so that it does not come out. If the release bushing is not pressed down sufficiently, there will be increased bite on the tube and it will become more difficult to pull it out.
 3. When the removed tube is to be used again, cut off the portion which has been chewed before reusing it. If the chewed portion of the tube is used as is, this can cause trouble such as air leakage or difficulty in removing the tube.
 - 3) Detaching of tube (ZFC100, 101)
(Perform with one hand.)
 1. Hold the collar of the release bushing with the thumb and index finger.
 2. Firmly grasp the tubing with the remaining three fingers and the palm of the hand.
 3. From this condition, while pushing in the release bushing with the thumb and index finger, pull the tube out with the three fingers and palm of your hand.
 4. To reuse the tubing which has been removed, first cut off the part which has been chewed up.
 - 4) In SMC's One-touch fitting series KQ2, do not install products with a metal rod on the pipe fittings of the series ZFC100/101. The metal rod will not be held and the fitting will fly off.

Precautions on Other Tube Brands

⚠ Caution

1. When using other than SMC brand tubes, confirm that the following specifications are satisfied with respect to the outside diameter tolerance of the tube.
 - 1) Nylon tube within $\pm 0.1\text{mm}$
 - 2) Soft nylon tube within $\pm 0.1\text{mm}$
 - 3) Polyurethane tube $+0.15\text{mm}$ or less
 -0.2mm or less

Do not use tubes which do not meet these outside diameter tolerances. It may not be possible to connect them, or they may cause other trouble, such as air leakage or the tube pulling out after connection.



Series ZFC Specific Product Precautions

Be sure to read before handling. Refer to pages 5 through 8 for safety instructions, vacuum equipment precautions and fitting and tubing precautions.

Selection

Warning

1. Do not use in lines where a pressurized condition is maintained, as the body may be damaged.

Mounting

Warning

1. Connect tubing to the IN and OUT One-touch fittings in accordance with the precautions for One-touch fittings.

Caution

1. Make connections after confirming the ► marks for IN and OUT indicated on the body. Proper sealing of the element cannot be guaranteed if connections are reversed.

Maintenance

Warning

1. When the element becomes clogged, stop operation and adjust the internal pressure of the filter to atmospheric pressure before replacing the element.

Caution

1. As a rule, replace the element when the pressure drops by 0.02MP.
2. During disassembly and assembly, confirm that there are no scratches or damage, etc., on the O-ring.



SMC'S GLOBAL MANUFACTURING, DISTRIBUTION AND SERVICE NETWORK

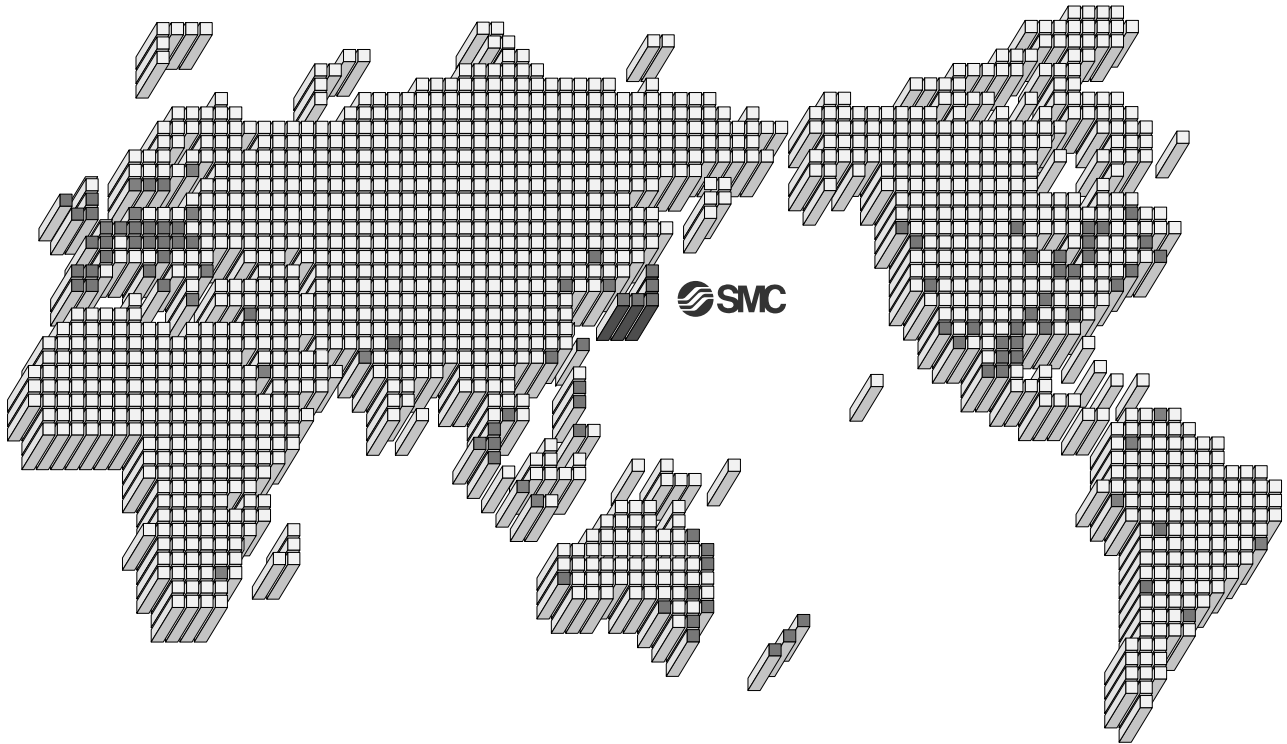

EUROPE

AUSTRIA

SMC Pneumatik GmbH

CZECH

SMC Czech s.r.o.

DENMARK

SMC Pneumatik A/S

FINLAND

SMC Pneumatiikka OY

FRANCE

SMC Pneumatique SA

GERMANY

SMC Pneumatik GmbH

HUNGARY

SMC Hungary Kft.

IRELAND

SMC Pneumatics (Ireland) Ltd.

ITALY/ROMANIA

SMC Italia S.p.A.

NETHERLANDS

SMC Pneumatics BV.

NORWAY

SMC Pneumatics Norway A/S

RUSSIA

SMC Pneumatik LLC.

SLOVAKIA

SMC Slovakia s.r.o.

SLOVENIA

SMC Slovenia d.o.c.

SPAIN/PORTUGAL

SMC España, S.A.

EUROPE

SWEDEN

SMC Pneumatics Sweden AB

SWITZERLAND

SMC Pneumatik AG.

UK

SMC Pneumatics (U.K.) Ltd.

ASIA

CHINA

SMC (China) Co., Ltd.

HONG KONG

SMC Pneumatics (Hong kong) Ltd.

INDIA

SMC Pneumatics (India) Pvt. Ltd.

MALAYSIA

SMC Pneumatics (S.E.A.) Sdn. Bhd.

PHILIPPINES

SMC Pneumatics (Philippines), Inc.

SINGAPORE

SMC Pneumatics (S.E.A.) Pte. Ltd.

SOUTH KOREA

SMC Pneumatics Korea Co., Ltd.

TAIWAN

SMC Pneumatics (Taiwan) Co., Ltd.

THAILAND

SMC Thailand Ltd.

NORTH AMERICA

CANADA

SMC Pneumatics (Canada) Ltd.

MEXICO

SMC Corporation (Mexico) S.A. de C.V.

USA

SMC Pneumatics, Inc.

SOUTH AMERICA

ARGENTINA

SMC Argentina S.A.

BOLIVIA

SMC Pneumatics Bolivia S.R.L.

BRAZIL

SMC Pneumaticos Do Brazil Ltda.

CHILE

SMC Pneumatics (Chile) S.A.

VENEZUELA

SMC Neumatica Venezuela S.A.

OCEANIA

AUSTRALIA

SMC Pneumatics (Australia) Pty. Ltd.

NEW ZEALAND

SMC Pneumatics (N.Z.) Ltd.

SMC CORPORATION

1-16-4 Shimbashi, Minato-ku, Tokyo 105-0004 JAPAN
Tel: 03-3502-2740 Fax: 03-3508-2480